

15MPa B型銅管くい込継手 (150kgf/cm²)

PF型

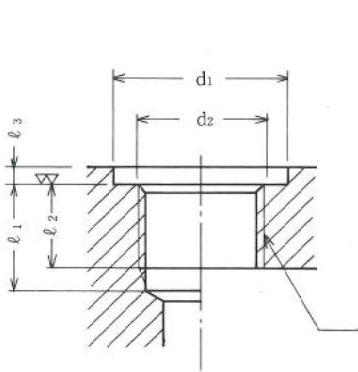

STRAIGHT THREAD CONNECTOR



銅ガスケット方式

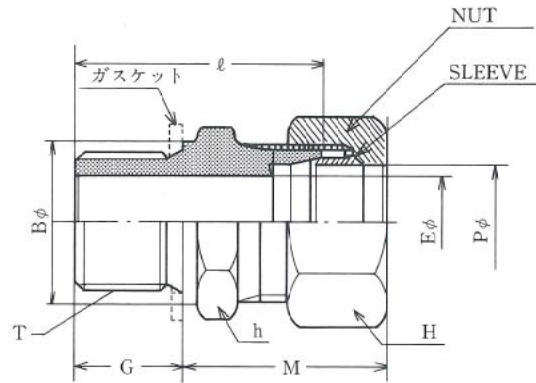

(注) L寸法はナットを締付け前の概略寸法を示す。

L denotes the rough dimensions before tightening the nuts. 単位：mm

継手の呼び方 Designation of joints	各部の記号 Symbols of respective parts	適用する管の外径 P 外 径 Tube O.D	E Minimum Opening	G	六角対辺 Opposite sides of hexagon		B	ℓ	(約) Appro M	G (PF)	対応する ガスケットの 呼び方 Designation for suitable gasket
					h	H					
GC 4 -G ¹ / ₈ -B		4	2.5	8	14	14	14	23	20	¹ / ₈	KP-A-01
GC 6 -G ¹ / ₈ -B		6	4	8	14	14	14	27	27.5	¹ / ₈	KP-A-01
GC 6 -G ¹ / ₄ -B		6	4	12	19	14	18	31	28.5	¹ / ₄	KP-A-03
GC 6 -G ³ / ₈ -B		6	4	12	23	14	21.5	34	28.5	³ / ₈	KP-A-05
GC 8 -G ¹ / ₈ -B		8	4	8	17	17	14	28	30	¹ / ₈	KP-A-01
GC 8 -G ¹ / ₄ -B		8	6	12	19	17	18	32	30	¹ / ₄	KP-A-03
GC 8 -G ³ / ₈ -B		8	6	12	23	17	21.5	34	28.5	³ / ₈	KP-A-05
GC10-G ¹ / ₄ -B		10	6	12	19	19	18	32	31.5	¹ / ₄	KP-A-03
GC10-G ³ / ₈ -B		10	8	12	23	19	21.5	34	31.5	³ / ₈	KP-A-05
GC12-G ¹ / ₄ -B		12	6	12	19	21	18	33	31.5	¹ / ₄	KP-A-03
GC12-G ³ / ₈ -B		12	8.5	12	23	21	21.5	34	31.5	³ / ₈	KP-A-05
GC15-G ³ / ₈ -B		15	8.5	12	23	26	21.5	37	34.5	³ / ₈	KP-A-05
GC15-G ¹ / ₂ -B		15	12	14	26	26	25.5	39	34.5	¹ / ₂	KP-A-07
GC16-G ¹ / ₂ -B		16	12	14	26	29	25.5	39	35.5	¹ / ₂	KP-A-07
GC18-G ¹ / ₂ -B		18	12	14	29	32	25.5	39	36.5	¹ / ₂	KP-A-07
GC20-G ³ / ₄ -B		20	16	16	32	35	31.5	42	36.5	³ / ₄	KP-A-11
GC22-G ³ / ₄ -B		22	16	16	32	36	31.5	42	36.5	³ / ₄	KP-A-11
GC25-G 1 -B		25	20	18	38	41	38	45	38.5	1	KP-A-16

銅ガスケット方式 ネジ寸法

PF	d ₁ (Min.)	d ₂ (Max.)	ℓ ₁	ℓ ₂ (Min.)	ℓ ₃ (Max.)
PF ¹ / ₈	18.2	10	15	10	1
PF ¹ / ₄	22.2	13.5	20	14	1
PF ³ / ₈	26.2	17	20	14	1
PF ¹ / ₂	32.2	21.3	25	17	1
PF ³ / ₄	38.2	27.0	27	19	1
PF 1	42.3	34	31	22	1

ガスケット	適応 ねじ	d	G	t
KP-A-01	PF ¹ / ₈	10	18	2
KP-A-03	PF ¹ / ₄	14	22	2
KP-A-05	PF ³ / ₈	17	26	2
KP-A-07	PF ¹ / ₂	22	32	2
KP-A-11	PF ³ / ₄	27	38	2
KP-A-16	PF 1	34	42	2

